

Identify parts before assembling.

Ax2
X Frame

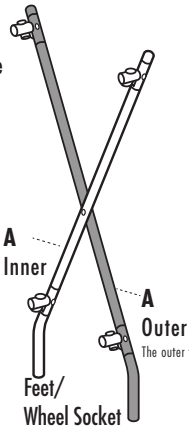

Bx2
15"
Long
Bar

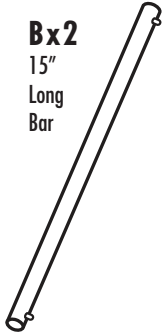

Cx2
13"
Short
Bar

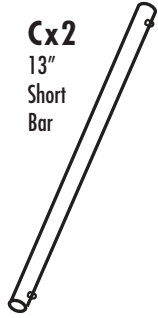

Dx1
Hamper
Bag

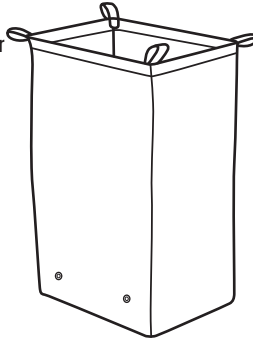

Ex4
2 Casters
2 Locking Casters

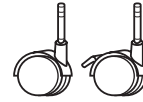

LH1002/LH1005

Fx4
28"
Elastic
Snap-on
Strap



Gx1
32"
Support
Strap

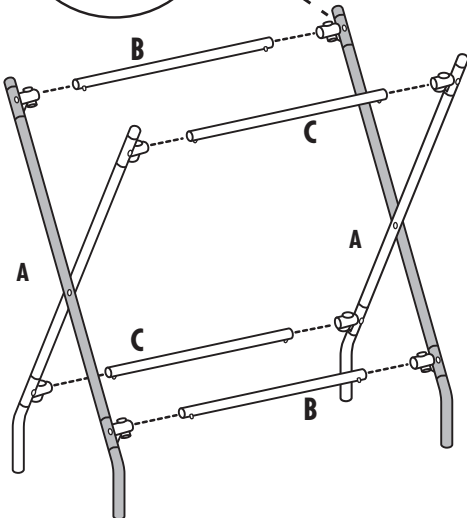
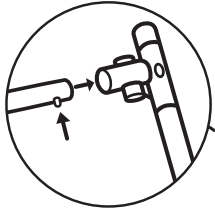

1. Set out all parts.
2. Attach bars to 1 x-frame (A).
 - a. Attach SHORT 13-inch bars (labeled part C) to the top and bottom of the x-frame's INNER LEG.
 - b. Attach LONG 15-inch bars (labeled part B) to the top and bottom of the x-frame's OUTER LEG.
3. Attach 2nd X-frame to bars, starting with the INNER LEGS. Connect INNER LEG to INNER LEG and OUTER LEG to OUTER LEG.

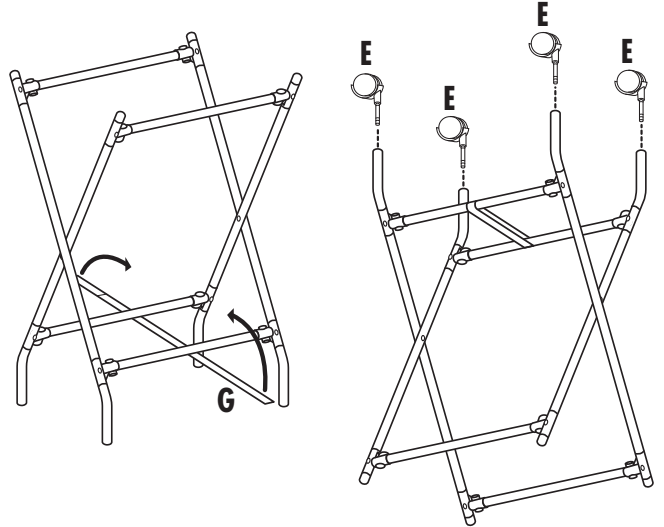

4. Wrap the hook and loop support strap (G) around the bottom bars.
5. Flip the frame upside down and push the wheels (E) into the feet until they "click" into place.

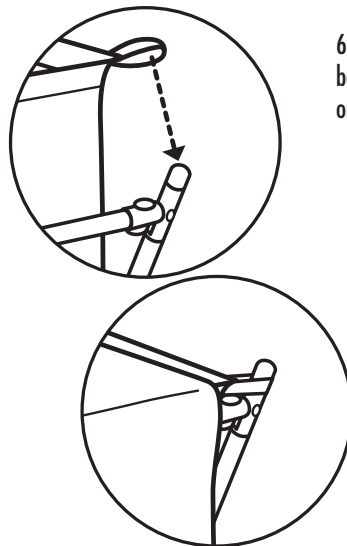
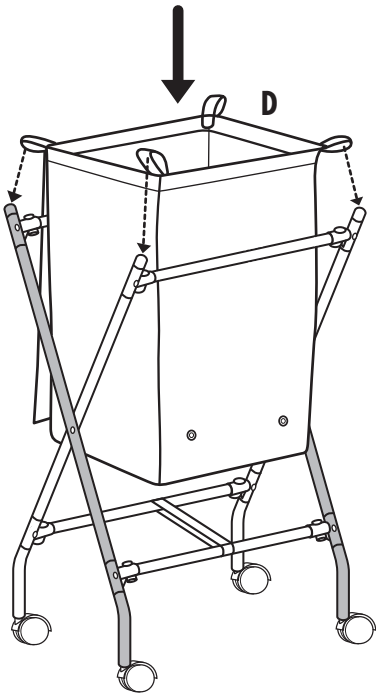

6. Set the frame upright and hang the bag (D) with the back of the bag looped onto the OUTER LEGS.

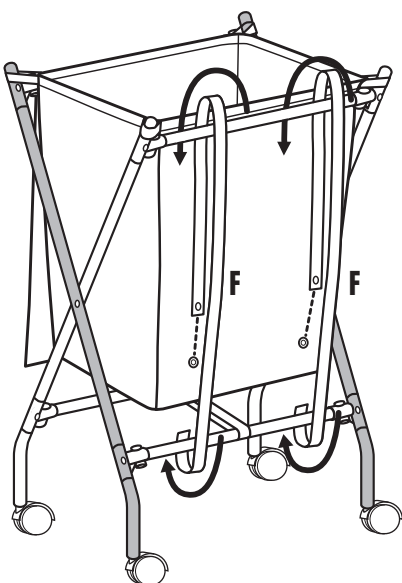
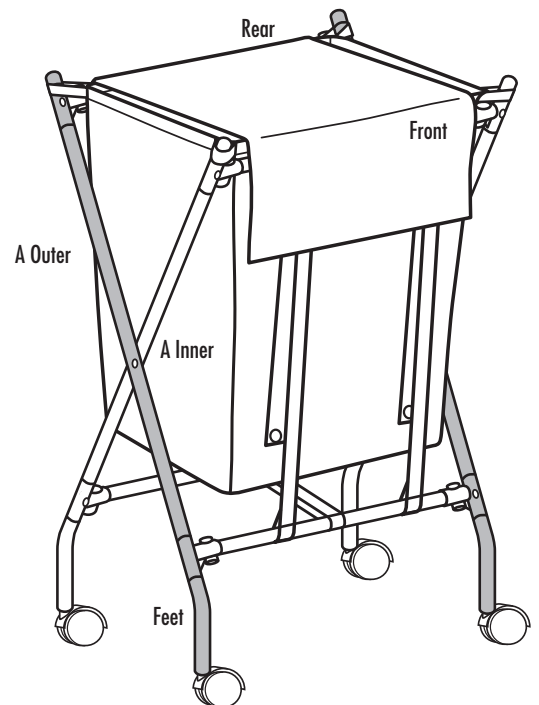

7. Snap one of the elastic straps (F) with a single snap to the hamper bag. Thread the strap over the top crossbar, then pull it down and snap it around the lower bar.

Repeat with remaining elastic straps.



©2016 HOUSEHOLD ESSENTIALS, LLC
Hazelwood, MO 63042
1-800-922-5524
1-314-428-5657

www.householdessentials.com

Made in China | Hecho en China | Fabriqué en Chine

Customer Service:

1-800-922-5524 • 1-314-428-5657